

## Globe valve Steel-straight/angle-fixed disc St.St. PN40

Globe valve cast steel straight / angle fixed disc St.St. PN40  
DIN 86251-01

Inner parts 1.4021+QT

Face to face lenght to DIN 3202/EN 558 F1/F32 flanges drill to DIN PN 40  
working pressure and temperature to DIN 2401

**material specification:**

body:	GP240GH+N	1.0619+N
bonnet:	GP240GH+N	1.0619+N
seat:	X20Cr13+QT	1.4021+QT
disc:	X20Cr13+QT	1.4021+QT
stem:	X20Cr13+QT	1.4021+QT

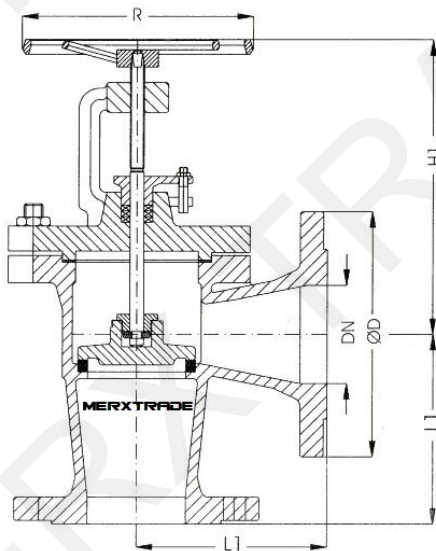

**MXT-11418100001**

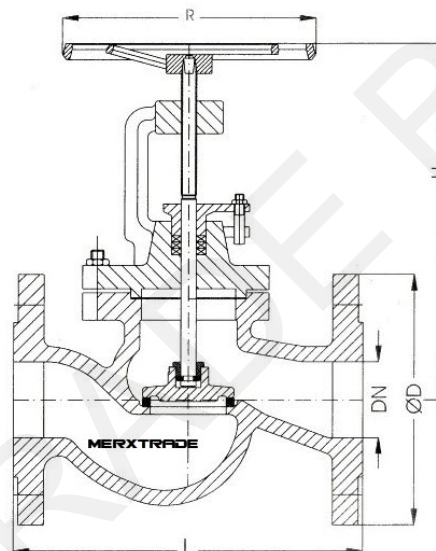

**Type MXT-11417100001**

NW/DN	L	L1	D	PCD	Holes	H	H1	R	KG straight	KG angle
15	130	90	95	65	4 x 14	195	185	120	3,9	4,1
20	150	95	105	75	4 x 14	210	185	120	4,6	4,7
25	160	100	115	85	4 x 14	230	185	140	6,3	4,9
32	180	105	140	100	4 x 18	265	260	160	7,5	11
40	200	115	150	110	4 x 18	290	270	180	11	14
50	230	125	165	125	4 x 18	315	275	200	14	16
65	290	145	185	145	8 x 18	355	320	220	22	28
80	310	155	200	160	8 x 18	410	370	250	26	37
100	350	175	235	190	8 x 22	440	405	300	51	48
125	400	200	270	220	8 x 26	470	435	350	64	60
150	480	225	300	250	8 x 26	520	495	400	105	76
200	600	275	375	320	12 x 30	570	575	400	176	153
250	730	325	450	385	12 x 33	685	610	400	254	188
300	850	375	515	450	16 x 33	780	675	520	414	327
350	980	425	580	510	16 x 36	860	760	640	857	430
400	1.100	475	660	585	16 x 39	880	760	640	1.150	767

Information provided as an indication and subject to possible modification.  
Colours and details can be different then shown in data sheets or pictures.  
Merxtrade BV has no liability for any damages by use off any information,  
displayed on these pages.